



OPERATOR'S MANUAL FOR ZTR-421, 422, 423 MOWER

ONE-YEAR LIMITED WARRANTY

This lawn mower is warranted for one(1) year from date of delivery against all defects in materials and workmanship. Lawn mowers used for commercial service are warranted for 30 days from date of delivery. (Lawn mowers other than those used only at residence of owner are considered as commercial service.)

Each new mower is warranted against manufacturing defects in material and workmanship under normal use and service. Our obligation, under this warranty, shall be limited to the replacement to the original retail purchaser of any part or parts, which, within the warranty period, shall be shown to be defective due to faulty workmanship or materials at the factory. All parts claimed defective must be returned to the factory for inspection, repair, or replacement with transportation charges prepaid.

This warranty does not apply to damage in transit or damage caused by misuse, negligence or accident, to alterations or repairs done outside the factory or authorized service stations, nor does it obligate us to assume any transportation charges in connection with the replacement of parts claimed to be defective.

Our warranty does not apply to the blades, adapters, chains or belts on our mowers due to the very nature of the function-they perform and to the elements they are exposed to.

The warranty specifically excludes engines, tires, and batteries which are warranted separately by their respective manufacturers. All claims for defective engines or engine parts must be made in accordance with the engine manufacturer's warranty.

We reserve the right to make changes in design and changes or improvements on our product without imposing any obligation upon ourselves to install the same on products heretofore manufactured.

This warranty is null and void if any parts other than original manufacturer's parts are used. There is no other express warranty.

IMPLIED WARRANTIES, including those of merchantability and fitness for a particular purpose, are limited to one(1) year from purchase and, to the extent permitted by law, any and all implied warranties are excluded.

IMPORTANT!

The Dixon ZTR mower is both easy and fun to operate. However, any power mower must be operated properly to be safe. It is not a toy or a recreational vehicle. Before you start to use the mower, read the operator's manual carefully, and become completely familiar with the controls. Your Dixon dealer will gladly provide a check-out ride, and answer any questions.

READ CAREFULLY

You have purchased a top quality lawn mower that has been inspected at the factory and found to be in perfect mechanical condition. This lawn mower is warranted for 1 year from date of delivery against all defects in materials and workmanship. Lawn mowers used for commercial service are warranted for 30 days from date of delivery.

SERIAL NUMBERS

The lawn mower has two serial numbers:

Mower Number — Located on frame at right rear transaxle mount. Transaxle Number — Located on transaxle.

SAFETY INSTRUCTIONS

BEFORE MOWING:

1. Discuss proper maintenance with your Dixon dealer, to save money and prevent injury. Consult your dealer before removing any parts.
2. Don't allow anyone to operate your Dixon mower without proper instruction. Young children should never be allowed to operate any power mower, riding or walking.
3. Before mowing, pick up all debris — particularly stones and sharp objects.
4. Before starting the engine, make sure the gas cap is in place.

DURING MOWER OPERATION

1. The revolutionary Dixon mower attracts many admiring neighbors. But when mowing, all persons — especially children — and pets should be cleared from the mowing area.

2. Wear appropriate, safe clothing when mowing — close-fitting jeans or slacks and heavy leather or safety shoes with rough soles. Never use any kind of mower with bare feet or open sandals, not even an old push-type model!
3. When grass is wet or slippery, do not use any riding mower.
4. Always mow at the slowest speed that will cut satisfactorily.
5. Keep hands and feet away from the blade at all times.
6. Although the Dixon mower is equipped with a missile deflector which directs downwards all blade propelled objects, keep persons clear of the discharge chute.
7. Your Dixon mower is very stable because of its low center of gravity and weight biased to the rear; however, caution should be exercised when mowing hills or slopes with *any* mower.
8. Always disengage blades before taking the mower

across walks or objects that project above the surface.

9. When the mower is not in use, turn the engine off; never leave the engine running unattended. Your Dixon mower is equipped with a weight-sensitive switch that kills the engine when operator leaves the seat while blades are engaged.
10. Before adjusting your mower or adding fuel, turn the engine off. Let it cool, and disconnect the spark plug so the engine cannot start by accident. Be sure all moving parts are stopped.

ALWAYS SET PARKING BRAKE AND DISENGAGE BLADE OPERATION BEFORE DISMOUNTING

IMPORTANT OPERATING INSTRUCTIONS

Dixon ZTR mowers offer a new concept in mowing, providing unique maneuverability and ease. The following procedures will allow one to become familiar with the unique method of control very easily.

1. SET PARKING BRAKE — Be sure that drive levers are free. (When drive levers are released, they will return to neutral position.)
2. Move "Blade Operation" lever to "Disengage" position. Engine will not start when blades are engaged.

11. Never run the engine indoors; the fumes are dangerous.
12. Before backing your Dixon mower, stop, turn around, and look.
13. Gasoline fumes are explosive; use only approved gasoline containers to store small amount of fuel. No special oil/gas mixtures are needed for your Dixon mower.
14. If the mower should start vibrating, stop the engine immediately and check for damage or loose parts. Vibration is usually the warning of trouble.
15. Never lift lawn mower by the body; lift only by the frame.

3. Move throttle control to "Choke" position.
4. To start models with electric starting, simply insert ignition key and turn to the far right position. When the engine starts, release the ignition key and it will remain in the "RUN" position. To stop the engine simply turn the key to the "OFF" position.

NOTE: Electric start models are also equipped with manual start provision. To start engine manually turn switch to "RUN" and pull the starter rope. To start manual start models, turn switch to "RUN" position. A sharp pull will start the engine. Release the start-

ing rope as soon as engine starts. To stop engine turn key to "OFF" position.

5. Set engine to desired speed by adjusting throttle control. (Suggest set at slow speed during initial operation.)
6. NOTE SAFETY FEATURE: Engine stops automatically if operator leaves seat while blades are engaged.
7. This unit is equipped with a unique transaxle that requires only two drive levers to control braking, turning, direction and acceleration. TO GO FORWARD:
From neutral position push both drive levers slightly forward; to increase speed move levers further forward. TO GO BACKWARD:
From neutral position pull both drive levers slightly rearward. TURNING:
Turning is controlled by moving one drive lever slightly forward or rearward of the other. To turn left, move left lever rearward of right lever. To turn "square corners" move lever of desired direction to neutral. To turn on mower's own axis (Zero radius) reduce speed and move one lever to reverse position and the other to forward position.

BRAKING:

To brake mower, move both levers in direction opposite of travel, release levers to neutral, set parking brake. When stopping on incline, it may be necessary to hold slight pressure on levers in direction opposite of slope, until parking brake is set.

ALWAYS SET PARKING.BRAKE BEFORE DISMOUNTING.

INITIAL OPERATION:

It is recommended that first operation of mower be done at a slow setting of throttle speed and disengagement of mower blades until operator is thoroughly familiar with the unit.

You may have tendency to "over control" mower at first. Slight movements — fingertip control — is all that's necessary for easy operation. 8. Mower Blade Operation:

- Cutting height is set by positioning the adjustment lever. Push button knob on top of lever, set desired cutting height, lock into position by releasing button knob.
- To start mower blades, move lever on floor to "engage" position. To stop mower blades, move lever to "disengage" position.

ALWAYS DISENGAGE BLADE OPERATION BEFORE DISMOUNTING.

9. Parking Brake:

Parking brake is on right hand side of floor area and is engaged by pushing full forward with foot. To disengage, pull lever back toward operator by hand. In emergency situations, brake may be used in conjunction with the natural braking of the transaxle by applying pressure with foot. Always set parking brake before dismounting. Be sure that parking brake is disengaged before moving.

MAINTENANCE

PRE-STARTING INSTRUCTIONS

1. Fill fuel tank with a good grade of regular gasoline. Do not mix oil with gasoline.
2. Attach the spark plug wire to the spark plug.
3. With mower on a level surface, fill the crankcase with a good grade of multi-purpose 10-30 oil as outlined in the engine instruction manual.
4. On model equipped with a battery be sure the battery is filled to proper fluid level with electrolyte solution. After initial filling, level may be retained with distilled water.

CAUTION:

5. During initial "Break In" period, the oil level should be checked often.
6. Check oil level every five operating hours or each time mower is used.
7. Change oil every 25 operating hours or sooner if equipment is operated in extremely dusty conditions.

BELT ADJUSTMENT

Main Drive Belt - This belt should be kept taut to lengthen belt life and prevent loss of power. To tension belt, loosen 4 bolts which hold the engine to the mount and the lock nut on the tension bolt at the rear of the machine. Tighten tension bolt until belt is taut and retighten the 4 bolts holding engine and tighten tension bolt lock nut.

MOWER DRIVE BELT

Belt tension for the mower drive belt is adjusted by turning the turnbuckle to provide more forward movement of the engaging idler.

REPLACE BELTS WHEN ADJUSTMENT CAN NO LONGER BE MADE SATISFACTORILY OR IF BELTS BECOME WORN.

BODY REMOVAL

A. ZTR-421 Body Removal

1. Disconnect throttle cable from engine.
2. Disconnect key switch wire loom from frame wire loom at front of body.
3. ^Disconnect seat switch wire loom from frame wire loom. This connection is located approximately level with the back of the seat on left hand side of frame under the body.
4. Remove four control lever bolts and remove upper control levers.
5. Remove engaging handle by removing bolt and nut under handle.
6. Disconnect brake pedal from brake pedal arm by removing the two bolts.
7. Remove two acorn nuts on front floor and the two sheet metal screws in transaxle body mount. This also removes the two brake arm clips. Body will lift clear. To replace body reverse the above procedure. When reinstalling the two screws in transaxle body mount, make certain brake arm retainer clips extend downward and are parallel with body mount.

B. ZTR-422 Body Removal

1. Disconnect throttle cable from engine.
2. Disconnect two wire loom plugs, one going to engine wires and one going to switch. Plugs are located between back of transaxle mount and battery.

OMIT STEP (3) AND FOLLOW ZTR-421 BODY REMOVAL INSTRUCTIONS FROM STEP (4) ON. REMEMBER TO REINSTALL SWITCH GROUND WIRE ON LEFT REAR TRANSAXLE BODY MOUNT SCREW.

C. ZTR-423 Body Removal

1. Disconnect throttle cable from engine.
2. Disconnect terminal running from motor terminal on switch to frame loom.
3. Disconnect seat switch plug from frame loom. This plug is located approximately even with back of seat on left hand side of frame under body.

FOLLOW ZTR-421 BODY REMOVAL INSTRUCTIONS FROM STEP (4) ON. REMEMBER TO REINSTALL SWITCH GROUND WIRE ON LEFT REAR TRANSAXLE BODY MOUNT SCREW.

CHAIN ADJUSTMENT

To adjust the drive chains, the body must be removed and shims added behind the transaxle. Loosen 4 bolts which hold the transaxle to the frame. Insert shims (Pt. No. 1541) as needed for adjustment between transaxle and mount plates. Tighten the 4 bolts which hold the transaxle to the frame. A few drops of oil periodically will lengthen chain life. Replace chain when rollers become loose, chain breaks, or chain fails to operate properly.

WHEELS AND TIRES

Correct tire pressure is essential to the correct operation of the machine. The correct pressure for the drive tires is 8-10 lbs. The front tires should be inflated to 30-35 lbs. Lug nuts should be checked periodically.

ELECTRICAL SYSTEMS

Keep all connections clean and tight. Maintain the fluid in the battery at correct level.

BODY

The body may be washed with a mild detergent and waxed with any automotive type wax.

ENGINE

Follow the manufacturer's instructions as to maintenance and repair.

TRANSAXLE

For adjustment or repair confer with authorized Dixon dealer service department. Adjustment or repair by other than authorized dealer voids warranty.

SERVICE LEGS

Service legs are located under the front end of the body of the unit. These legs serve as additional weight for the front end of the mower, and when lowered, give service access to the mower deck without having to remove this assembly.

To lower these service legs:

1. Set parking brake.
2. Raise mower deck to top position.
3. For safety, support the service legs so that they will not fall. Loosen and remove the four nuts and two bottom plates from the U-bolts. Then remove the support and lower service legs to ground.
4. Raise front end of unit and move the service legs into position, spreading them as wide as possible to achieve maximum stability.

SPARE PARTS

See your dealer for ordering spare parts or warranty service.

INSTALLING AND REMOVING MOWER DECK FROM FRAME

1. Attach stabilizer arms to mower deck with pins and clips as shown on drawing.
2. Attach the 1/2" dia. engaging rod with a rollpin through the engaging cam.
3. Position the drive belt on pulleys.
4. Place mower deck under unit in approximate operating position with engaging rod through hole in the floor.
5. Connect drive belt to motor pulley, being certain that belt is inside of belt guides. Loosen belt keeper by loosening the two rear engine mount bolts; this will allow belt to be placed on motor pulley. Retighten engine mount bolts.
6. Attach stabilizer arms to pivot point on the inside of attaching plates with pins and clips.
7. Attach lift linkage to mower deck on the inside of the attaching lugs as shown on drawing with pins and clips. (4 places)
8. Place engaging handle on engaging rod and fasten with bolt and locknut.
9. Connect pan wire loom plug to plug on frame wire loom. Mower will not start unless this connection is

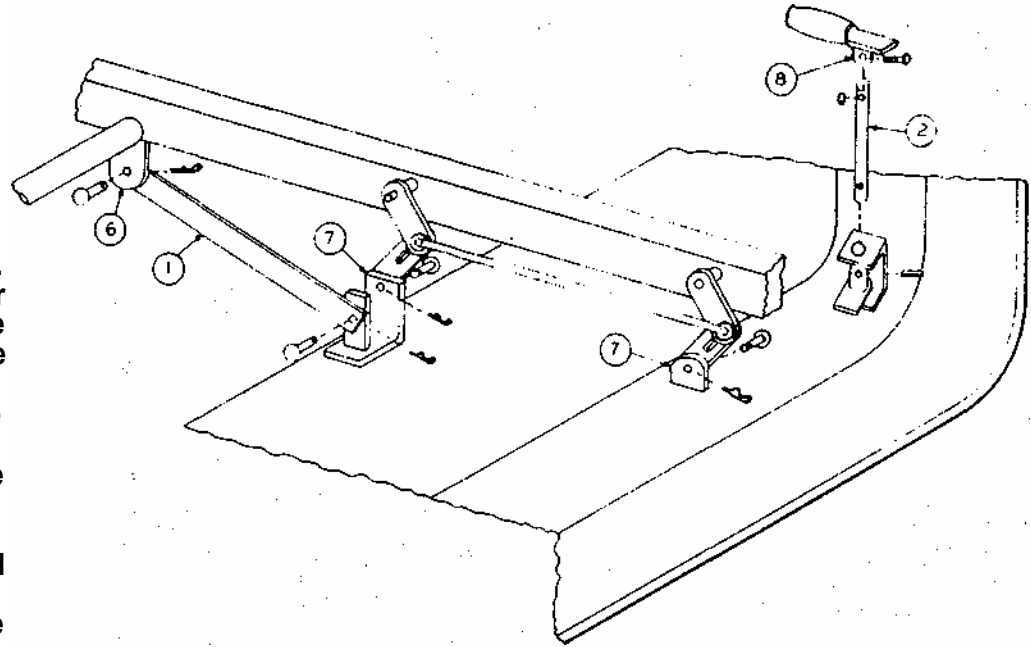

made. To operate mower with pan removed an available by-pass (P/N 4038) must be used.

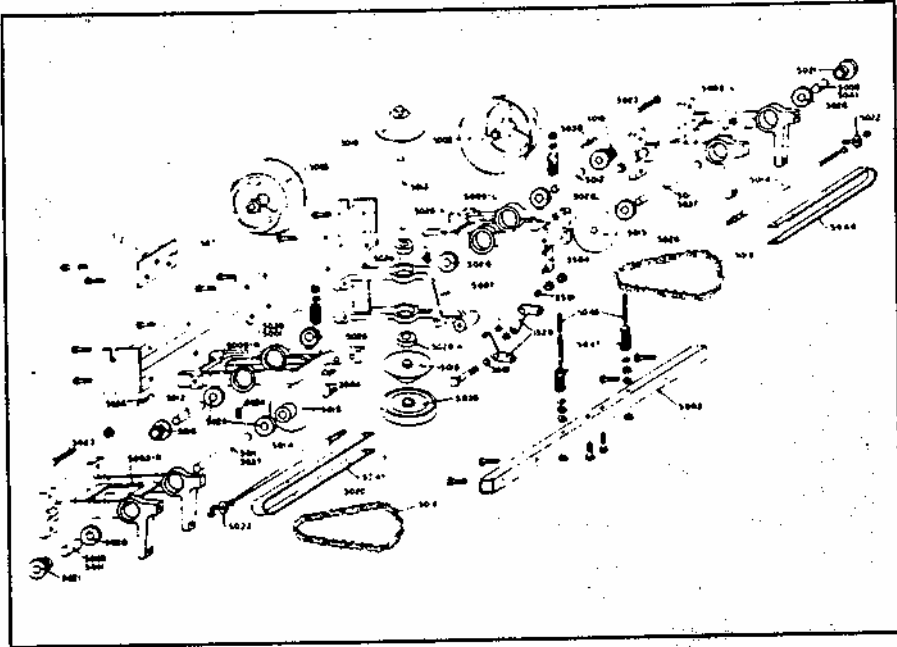

TRANSAXLE ASSEMBLY

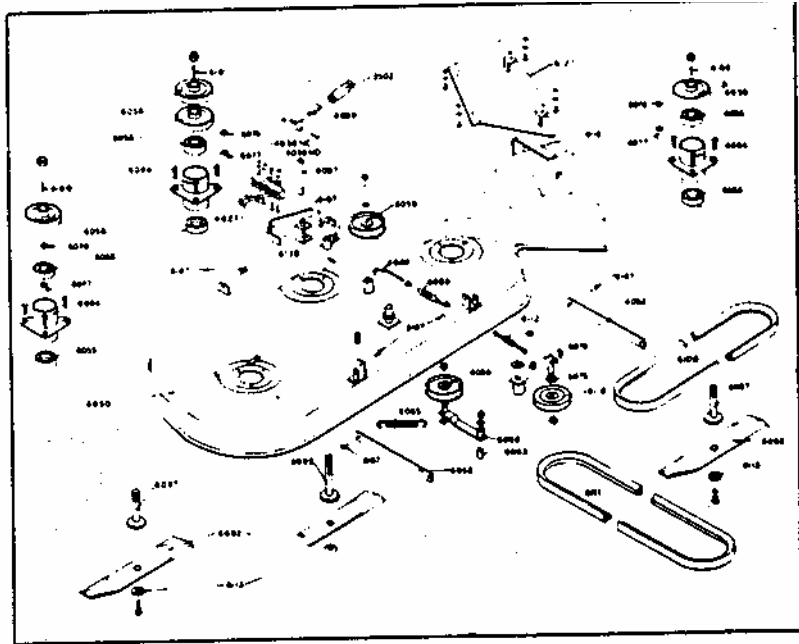

MOWER DECK ASSEMBLY

PARTS LIST

Part No.	Name	Part No.	Name	Part No.	Name
1000	Frame Weldment (Electric)	1542	V-Pulley	4005	Throttle Cable
1015	Caster Assembly	1543	Lift Knob	4006-1	Battery Solenoid Cable
1020	Caster Axle	1552	Belt Keeper	4006-2	Battery Ground Cable
1022	Caster Wheel & Tire	1560	Battery Splash Guard	4006-3	Solenoid-Alternator Cable
1029L	Lift Lever & Quadrant Left	1564	Brake Arm 75 Model	4006-4	Swith-Headlight Cables, ZTR-421
1039	Lower Lift Link	1567	Brake Mount 75 Model	4006-5	Front Loom Assy. Prior to 75
1040	Lift Tie Rod	1574	Brake Pivot 75 Model	4006-6	Rear Loom Assy. Prior to 75
1043	Battery Strap	1579	Short Brake Rod 75 Model	4006-7	Rear Loom Assy., ZTR-422
1100	Frame Weldment (Manual)	1580	Long Brake Rod 75 Model	4007	Battery
1500	Lower Control Lever	1581	Brake Pedal Arm 75 Model	4008	Solenoid
1501R	Upper Control Lever Right	1584	Brake Pedal 75 Model	4009	Wire Clip
1501L	Upper Control Lever Left	3025	$\frac{1}{4}$ x 1 Spiral Pin	4010	Control Decal
1502	Control Rod Assembly	3026	$\frac{1}{4}$ x 1 $\frac{1}{2}$ Spiral Pin	4011	Name Decal
1504	Wheel Hub & Sprocket	3029	Front Grommet	4014	Standard Seat 18"
1507	Wheel Bearings	3030	Rear Grommet	4025	Switch Decal
1509	Wheel& Tire	3054	$\frac{3}{16}$ x 1 Roll Pin	4027	Pan Loom ZTR-421, ZTR-422
1528	Bellcrank	3070	$\frac{1}{4}$ x 1 $\frac{1}{4}$ Spiral Pin	4028	Frame Wire Loom, ZTR-422
1535	Chain	3501	Nylon Bushing	4029	Switch Wire Loom, ZTR-422
1536	Connecting Link	3502	Hand Grip	4030	Seat Switch Wire Loom, ZTR-421
1538	V-Pulley	3504	Double Ball Joint	4031	Frame Wire Loom, ZTR-421
1539	Drive V-Belt	4002	Deluxe Seat 36", ZTR-421	4032	Pan Wire Loom, ZTR-423
1540	Key	4003	Headlight	4033	Frame Wire Loom. ZTR-423
1541	Shim	4004	Switch	4034	Switch Wire Loom, ZTR-423

Part No.	Name
4035	Switchground Wire, ZTR-423
4036	Micro Switch
4037	Front Wire Loom, ZTR-421
4038	Pan By-Pass Plug
4050	Body-White
4051	Body - Blue
5000	Transaxle
5003L	Support - Left
5003R	Support - Right
5004R	Support Assembly Right
5004L	Support Assembly Left
5005	Discup
5006	Spacer
5007	Center Frame
5009L	Cradle - Left
5009R	Cradle - Right
5010R	Cradle Assembly Right
5010L	Cradle Assembly Left
5011	Support Shaft
5012	Cradle Shaft
5013	Frame Shaft
5014	Torque Rod
5015	24 T Sprocket
5016	Cone

Part No.	Name
5018	9 T Sprocket - Narrow
5019	Chain
5021	9 T Sprocket - Wide
5022	Thumb Screw
5023-1	Pivot Bolt
5024	Cradle Spring
5025	Frame Assembly
5028	Bearing
5028-A	Bearing - Notched
5035	Transaxle Pulley
5036	Pivot Spring
5044	Torque Rod Stiffner Kit
5050	Positive Neutral Kit
6025	Mower Deck Assembly
6050	Mower Deck Weldment
6052	Stabilizer Arm
6055	Mower Bearing
6058	V-Pulley
6059	Flat Idler Pulley
6060	Serpentine Idler Bracket
6063	Bronze Bushing
6065	Tension Spring
6070	Engaging Idler Bracket
6075	Spacer

Part No.	Name
6077	Bearing Spacer
6078	Pulley Spacer
6086	Connecting Link
6087	Engaging Rod
6088	Turnbuckle
6089	Engaging Handle
6092	Blade
6093	Outer Hub Assembly
6094	Hub
6095	Center Shaft Assembly
6097	Outer Shaft Assembly
6100	Key
6101	Key
6107	Pin
6108	Center Hub Assembly
6109	V-Belt
6110	V-Idler Pulley
6111	V-Belt
6112	Engaging Spring
6113	Blade Washer
6119	Decal
6127	Deflector Assembly
6130	Engaging & Switch Cam 75

OWNER INFORMATION

Date Mower Purchased _____ Mower Model Number _____

Mower Purchased from _____
dealer name & address

Mower serial number _____ Transaxle Serial Number _____

Oil changed this date:

- 1. _____
- 2. _____
- 3. _____

- 4. _____
- 5. _____
- 6. _____

Engine tuned this date:

- 1. _____
- 2. _____

- 3. _____
- 4. _____

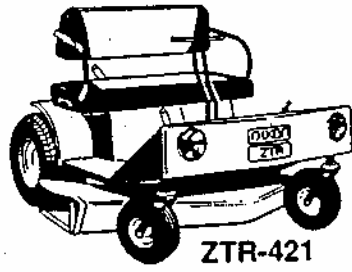

© Dixon and ZTR are the trademarks of Dixon Industries Inc. Box 494 Coffeyville, Kansas 67337

FORM NO. 812-476

LITHO IN U.S.A.